

SC150



Standard Signal Conditioner for 100mV/g Accelerometers with 4-20 mA Proportional Output and User Selectable 0-10 or 0-5V Output

VIBRATION ANALYSIS HARDWARE



Product Features

Vibration data can be monitored by control room personnel, without any knowledge of vibration signals. The SC150 Series units provide process control signals to a PLC, DCS, or SCADA system, in 4-20 mA outputs, along with selectable 0-5 VDC or 0-10 VDC signals, that are proportional to the vibration levels set within the signal conditioner.

The SC150 Series also provides dynamic data to be collected for analysis with conventional Vibration Data Acquisition systems.

- ▶ Factory Set to 100 mV/g accelerometer input, 0-2 IPS, RMS, 4-20 mA Output with user configurable selections for 0-5 V or 0-10 V Output and IEPE Power Enabled or Disabled, and 2 Hz to 1 kHz or 10 Hz to 1 kHz filters
- ▶ Can be used with CTC's FREE Signal Conditioner Configuration Software, which enables easy reconfiguration of user selectable variables in the field

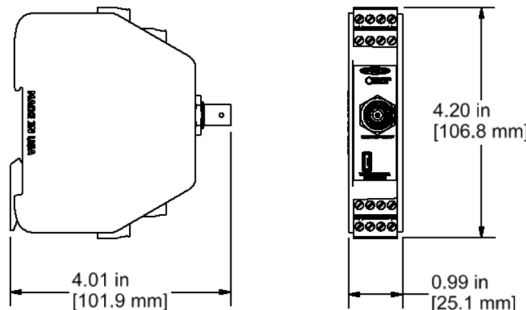

Specifications

Output	4-20 mA output signal for vibration (0-1.2 VDC input) Can use shared common for control IO compatibility without isolators
Humidity Range	0-95% relative, non-condensing
Connectors	Screw Terminals, detachable
Input Power	24 to 30 VDC unregulated / 200 mA maximum
Sensor Power	24 VDC, 4 mA DC sensor excitation
Max Load Resistance	600 ohms
Isolation	1000 VDC
Temperature Range	-40 to 158 °F (-40 to 70 °C)

Built to Order

Cooling is required if enclosure temperature exceeds 140 °F (60 °C)

Ordering Information

SC150 - - -

Signal Conditioner	IEPE Power	Voltage Output Range	ISO Filter
	PE = IEPE ON PD = IEPE OFF	05 = 0-5 V 10 = 0-10 V	00 = 2 Hz - 1 kHz 01 = 10 Hz - 1 kHz

Backed by our Unconditional Lifetime Warranty