

MH145-1B

Accelerometer Mounting Pad with Button Head Grease Fitting Adapter, 1/8-27 NPT Mounting Thread



VIBRATION ANALYSIS HARDWARE



Product Features

Sensor Can Be Mounted Directly into a Grease Fitting Location

- ▶ 1/4-28 Accelerometer mounting hole
- ▶ Zerk fitting included
- ▶ Stainless steel case material

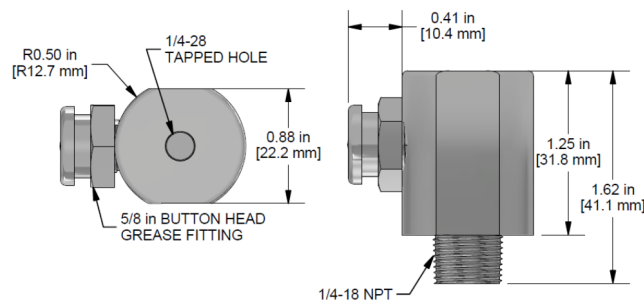

Specifications

Case Material	Stainless Steel
Dimensions	1.62 in. (41 mm) x 0.88 in. (22 mm)
Sensor Mounting	1/8-27 NPT Mounting Thread 1/4-28 Accelerometer Mounting Hole

Chemical Compatibilities for Reference

- ▶ Gasoline - A
- ▶ Methanol - A
- ▶ Lubricants - A

Compatibility

- ▶ Compatible with any accelerometer with 1/4-28 stud or adapter
- ▶ Conversion mounting studs available

Stock Product

Backed by our Unconditional Lifetime Warranty

www.ctconline.com | sales@ctconline.com | 585-924-5900