

MH130-1T

Mounting Disk with 1/4-28 Blind Tapped Hole and Triaxial Accelerometer Locating Notch, 1.0 in. (25.4 mm) Diameter



VIBRATION ANALYSIS HARDWARE



Product Features

Triaxial alignment notch ensures receptacle engagement with CTC triaxial accelerometers

- ▶ Provides a consistent location for permanent vibration measurement readings
- ▶ Stainless steel construction attracts to portable measurements and corrosion resistance
- ▶ Mounted with adhesive - no drilling and tapping required

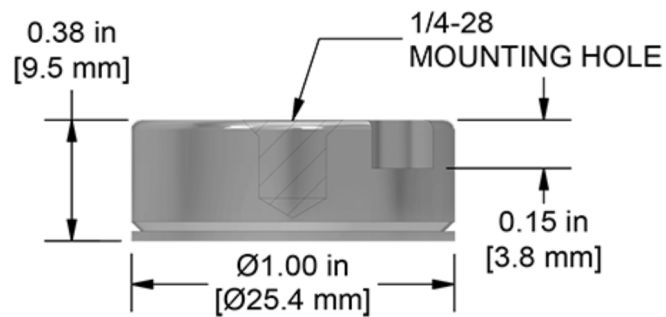

Specifications

Case Material	17-4 Stainless Steel
Sensor Mounting	1/4-28 Blind Tapped Hole

Chemical Compatibilities for Reference

- ▶ Gasoline - A
- ▶ Methanol - A
- ▶ Lubricants - A

Compatibility

- ▶ Suited for CTC Triaxial accelerometers

Stock Product

Backed by our Unconditional Lifetime Warranty

www.ctconline.com | sales@ctconline.com | 585-924-5900