

C10 Series



VIBRATION ANALYSIS HARDWARE

IRD Balancing Model 943 Accelerometer Compatible, 5 Pin Right Angle LEMO® Connector, Single Channel Acceleration Input, Pin 1 Common (-), Pin 5 Signal/Power, Shield/Drain Tied to Case

Product Features

5 Pin Right Angle LEMO® Connector

Designed for use with IRD Model 843 100 mV/g seismic accelerometer

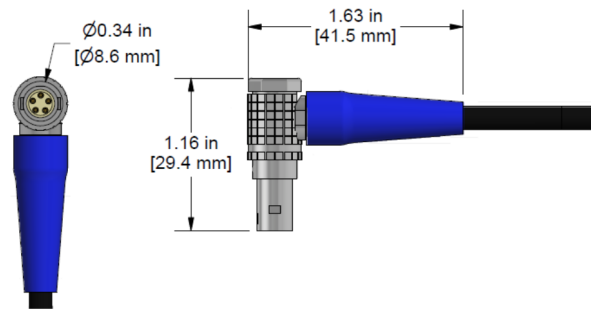

Specifications

Application	Portable
Max Temperature	482 °F (250 °C)
Temperature Range	-67 °F - 482 °F (-55 °C - 250 °C)
Strain Relief	Polyurethane
Shell Material	Chrome-plated Brass
Pin-Out	Pin 1 = Common (-) Pin 5 = Signal/Power

Built to Order

Backed by our Unconditional Lifetime Warranty

www.ctconline.com | sales@ctconline.com | 585-924-5900